

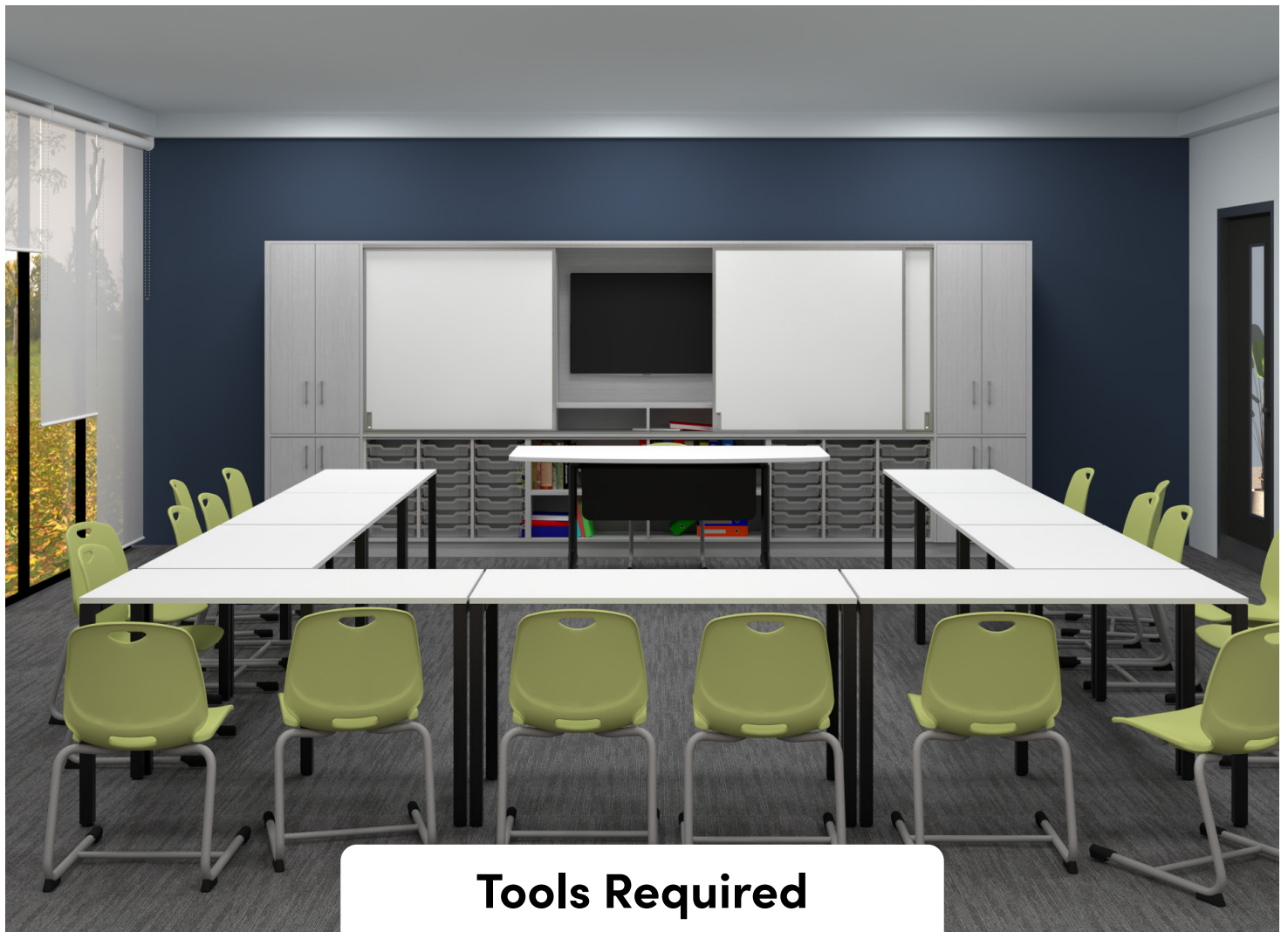

AVERO DESK **ASSEMBLY GUIDE**





Tools Required



Battery Drill



Phillips Driver Tip

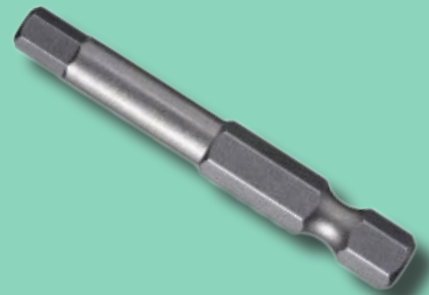

4mm Hex Bit

Accent
workspace furniture solutions

TABLE OF CONTENTS

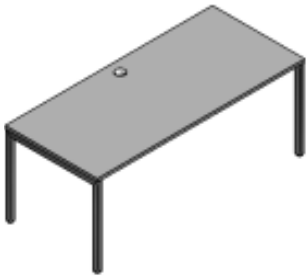
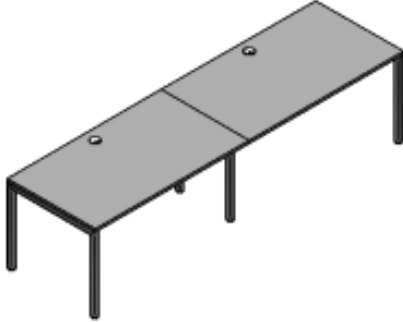
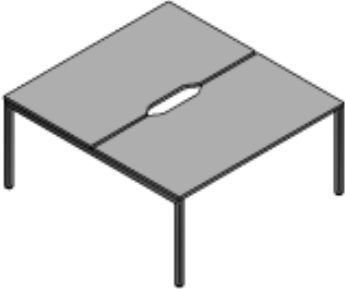
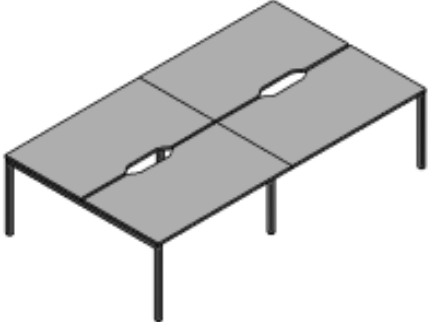
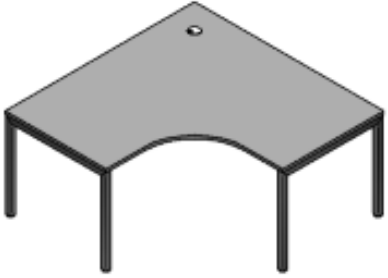
CONFIGURATION	PAGE NUMBER	IMAGE
Straight Desk	4-6	
Inline 2pod	7-9	
Back-to-Back 2Pod	10-11	
Back-to-Back 4pod	12-14	
Corner Workstation	15-17	

STRAIGHT DESK

PARTS LIST

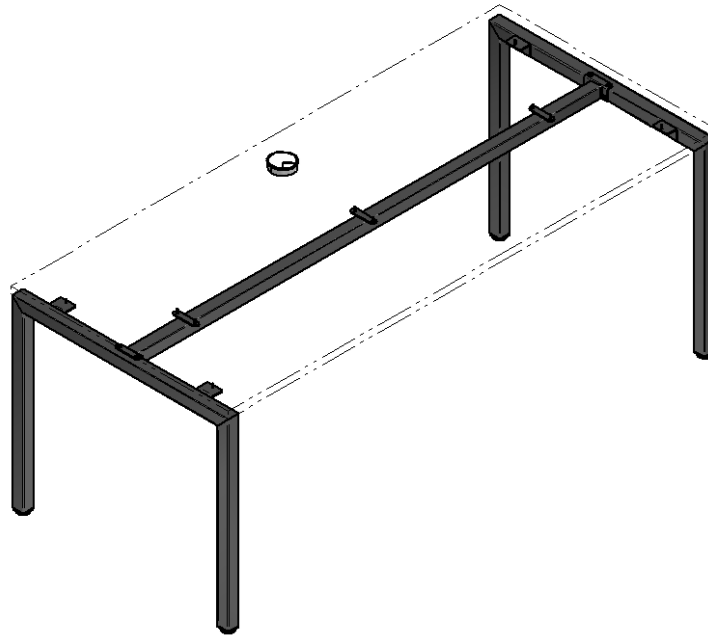

NO.	NAME	QUANTITY	IMAGE
1	Desk Top	1pc	
2	Leg Frame	2pcs	
3	Fixed Beam	1pc	
4	Cable Entry	1pc	
5	Wood Screw	10pcs	
6	CSK Bolts	4pcs	
7	Flat Head Bolt	4pcs	

STRAIGHT DESK

ASSEMBLY INSTRUCTION

STEP 1

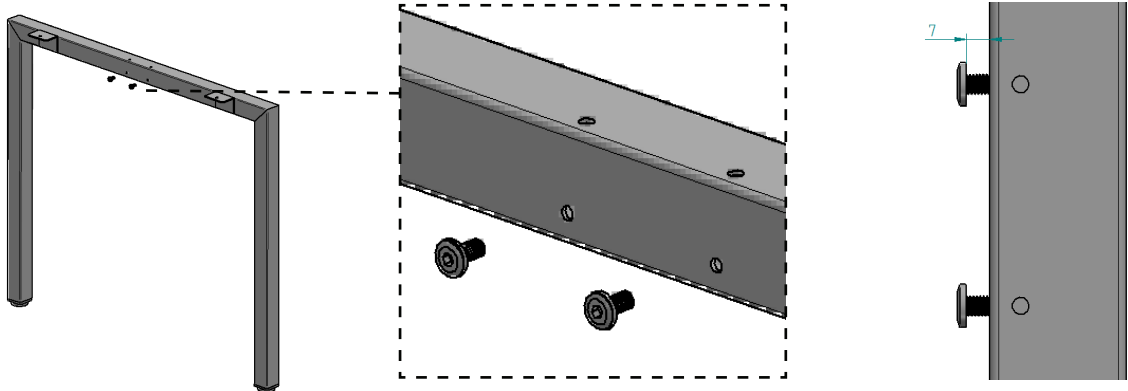

Install flat head bolts to the side of the leg. Note: Ensure the flat head bolt is installed with the head protruding approximately 7mm from the surface. This spacing is necessary for the next step.

STEP 2

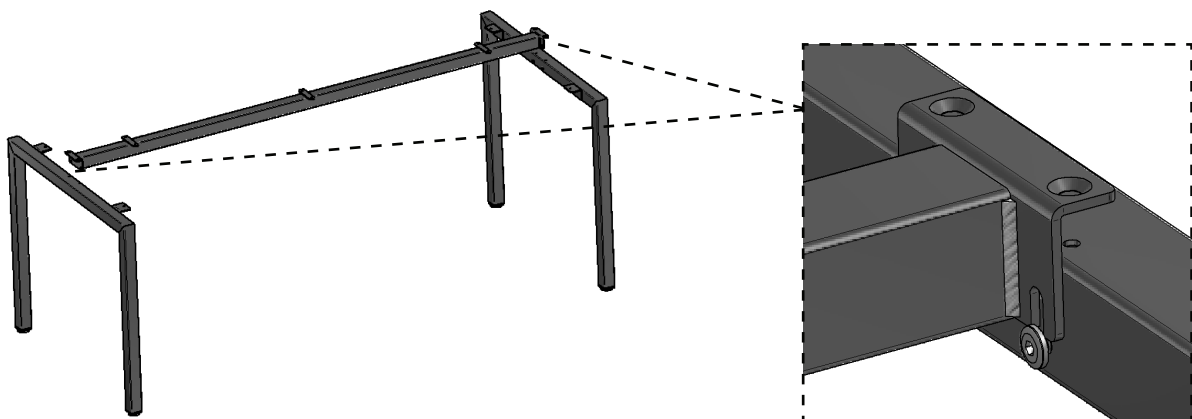

Attach the beam to the leg.

STEP 3

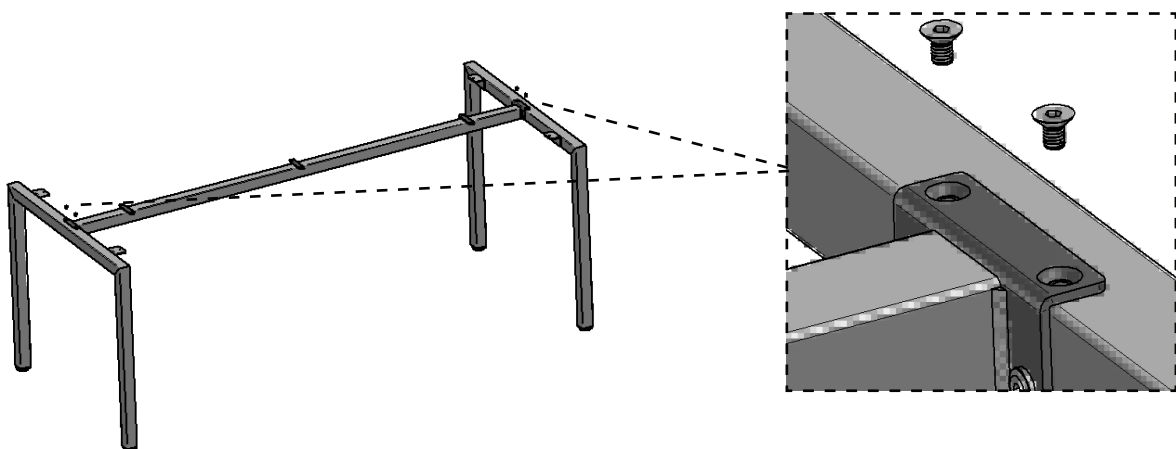

Install bolts to the top of the leg frame. Tighten bolts on the top and side for the leg. *Do not overtighten – excessive force may strip threads or damage component.*

STRAIGHT DESK

ASSEMBLY INSTRUCTION

STEP 4

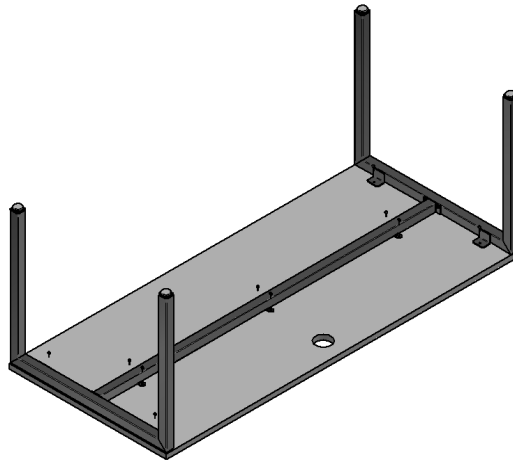

Place the table top upside down on a clean flat surface. Attach the frame to the desktop.

STEP 5

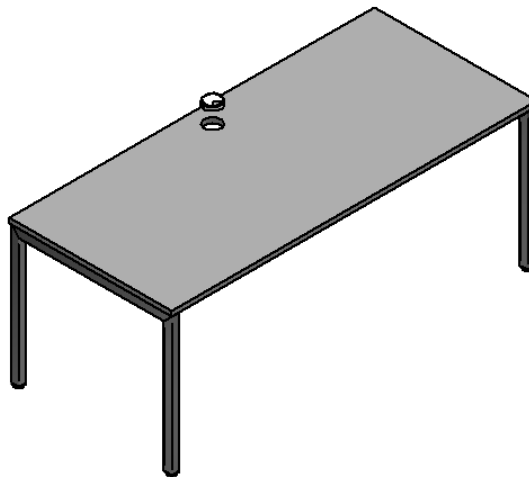

Install the cable entry.



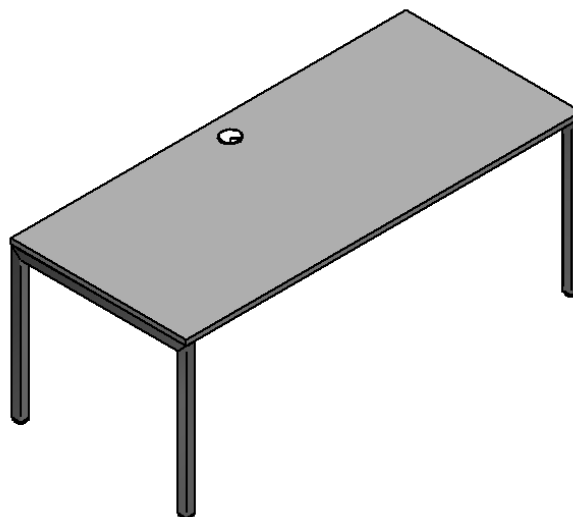

STEP 6

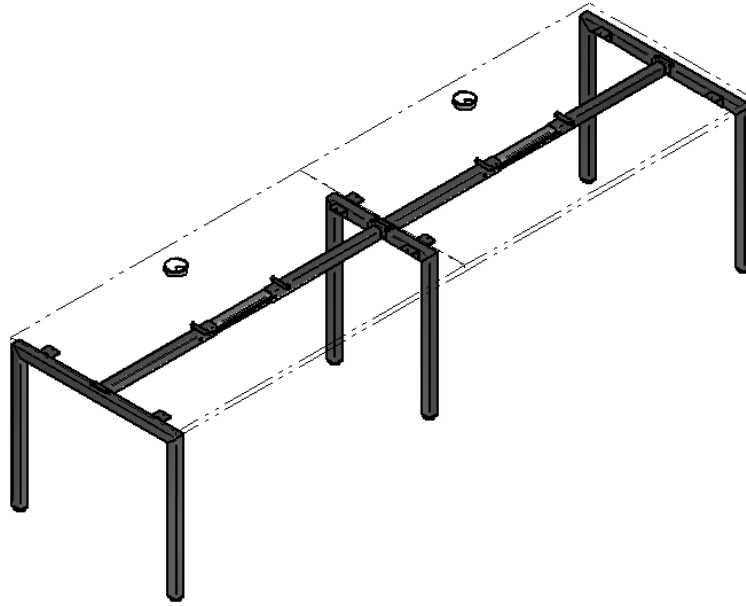

INLINE DESK 2POD

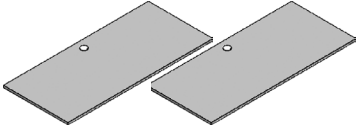
PARTS LIST

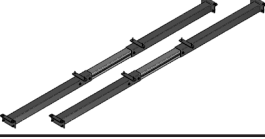
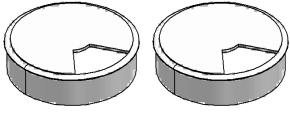
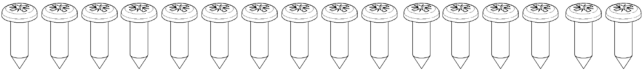

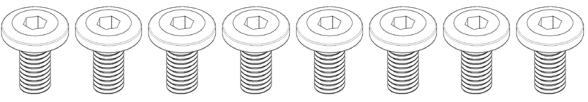
NO.	NAME	QUANTITY	IMAGE
1	Desk Top	2pcs	
2	Leg Frame	2pcs	
3	Middle Leg Frame	1pc	
4	Extendable Beam	2pcs	
5	Cable Entry	2pcs	
6	Wood Screw	16pcs	
7	CSK Bolt	8pcs	
8	Flat Head Bolt	8pcs	

INLINE DESK 2POD

ASSEMBLY INSTRUCTION

STEP 1

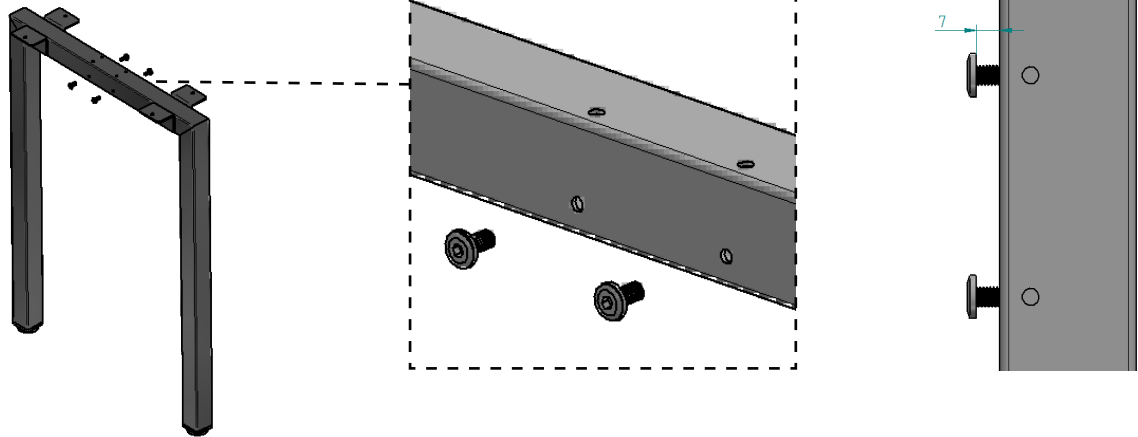

Install flat head bolts to the side of the leg. Note: Ensure the flat head bolt is installed with the head protruding approximately 7mm from the surface. This spacing is necessary for the next step.

STEP 2

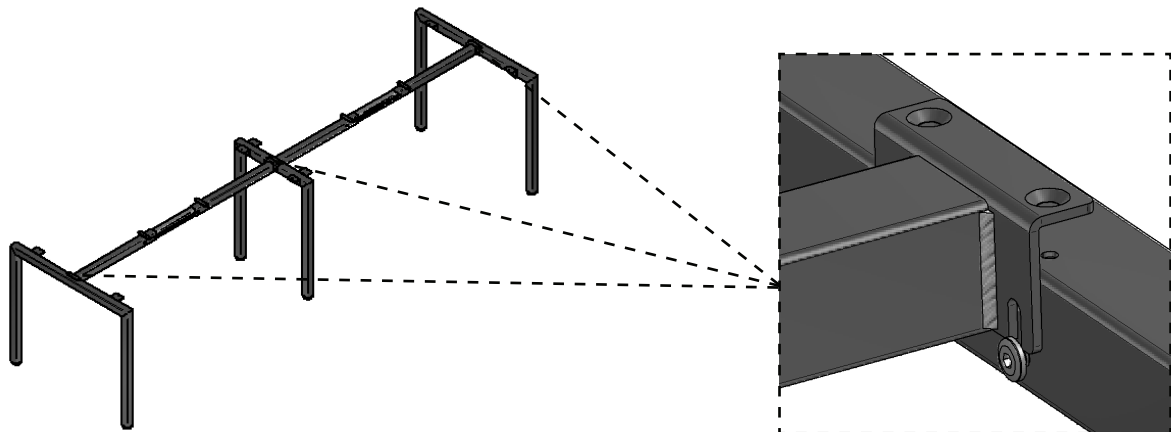

Attach the beam to the leg.

STEP 3

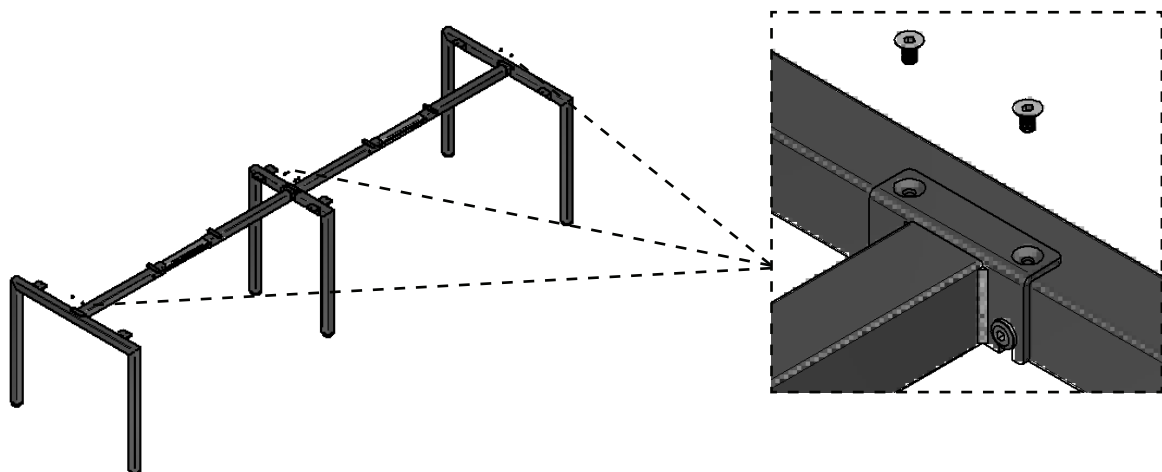

Install bolts to the top of the leg frame. Tighten bolts on the top and side for the leg.
Do not overtighten – excessive force may strip threads or damage component.

INLINE DESK 2POD

ASSEMBLY INSTRUCTION

STEP 4

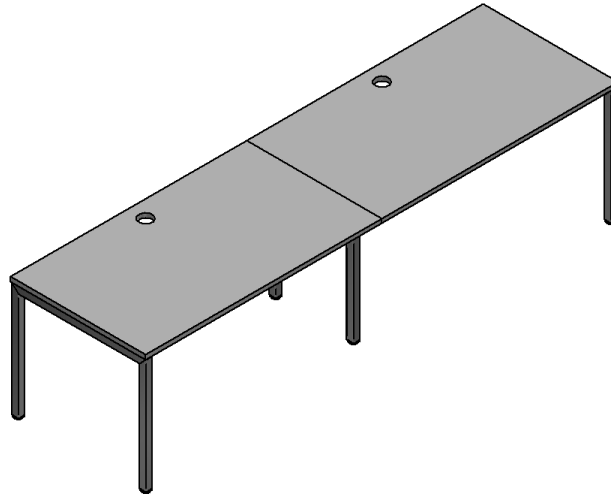

Place Desktops onto the frame. Attached frame to desktop.

STEP 5

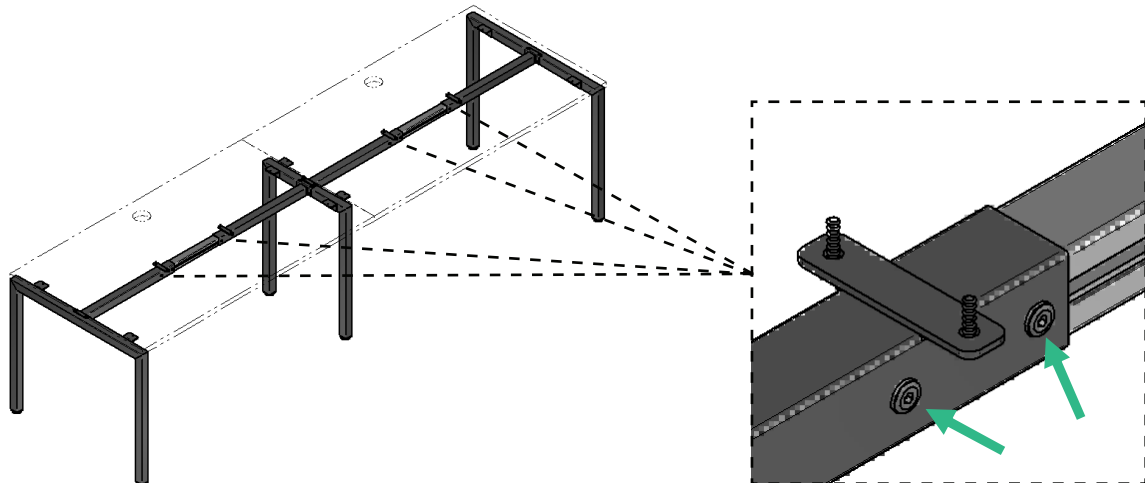

Tighten flat head bolts on the front and back of the beam.

STEP 6

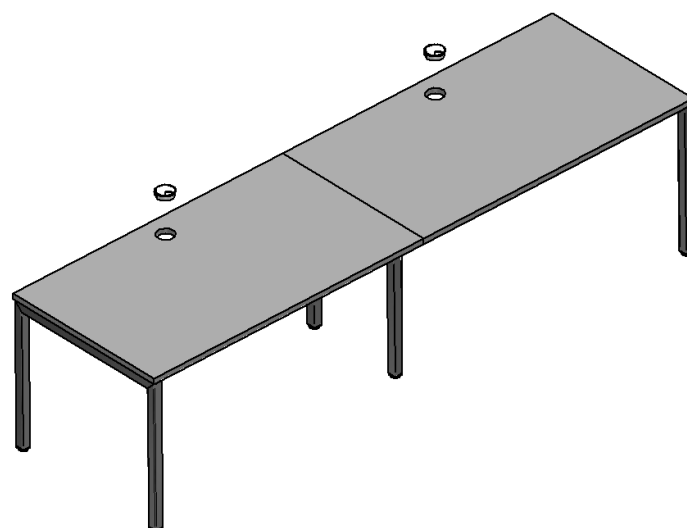



Install the cable entry

BACK-TO-BACK 2POD

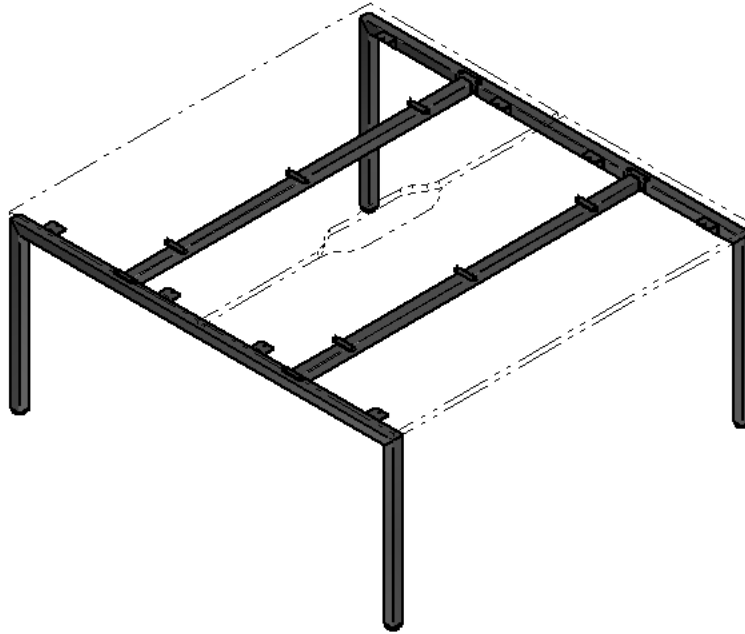
PARTS LIST

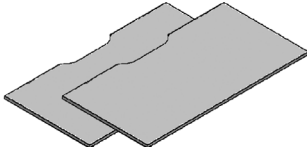
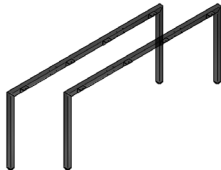
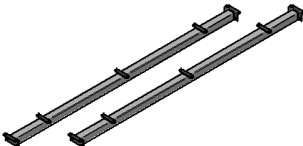
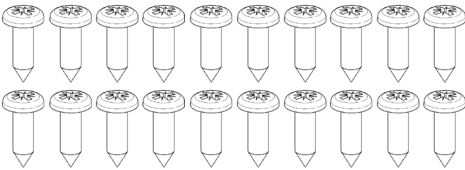

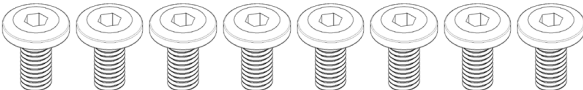
NO.	NAME	QUANTITY	IMAGE
1	Desk Top	2pcs	
2	End Leg Frame	2pcs	
3	Fixed Beam	2pcs	
4	Wood Screw	20pcs	
5	CSK Bolt	8pcs	
6	Flat Head Bolt	8pcs	

BACK-TO-BACK 2POD

ASSEMBLY INSTRUCTION

STEP 1

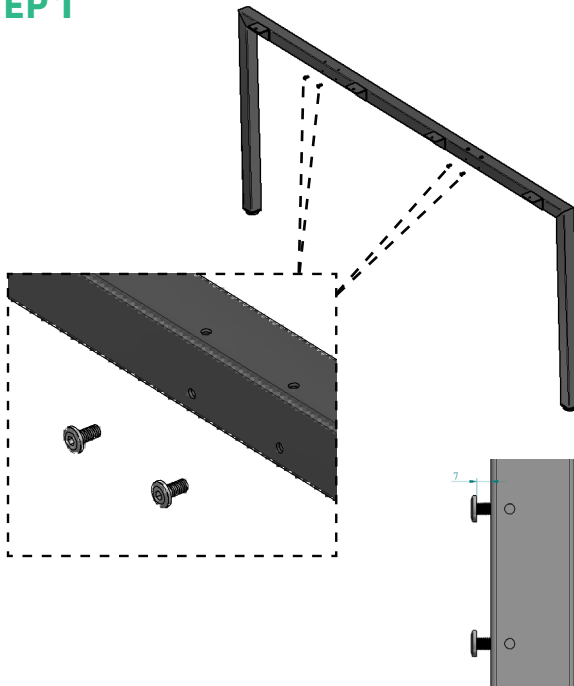

Install flat head bolts to the side of the leg.
Note: Ensure the flat head bolt is installed with the head protruding approximately 7mm from the surface. This spacing is necessary for the next step.

STEP 2

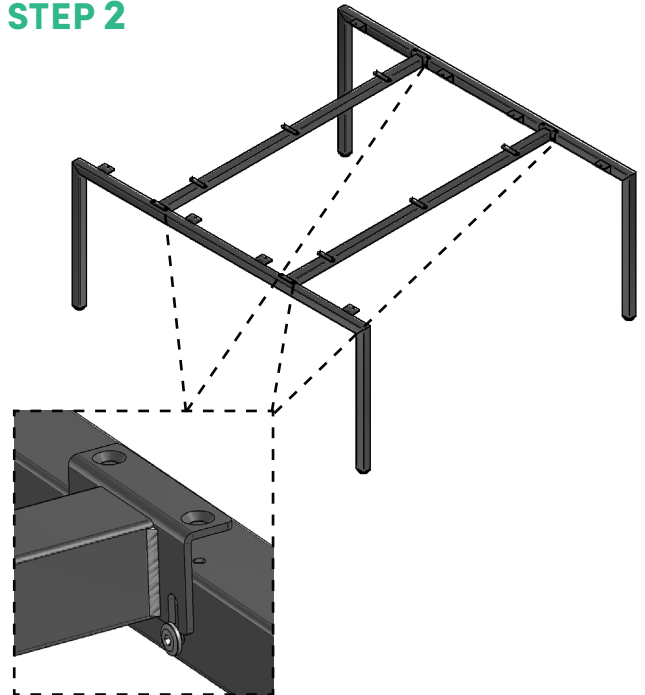

Place the beam onto the leg frame

STEP 3

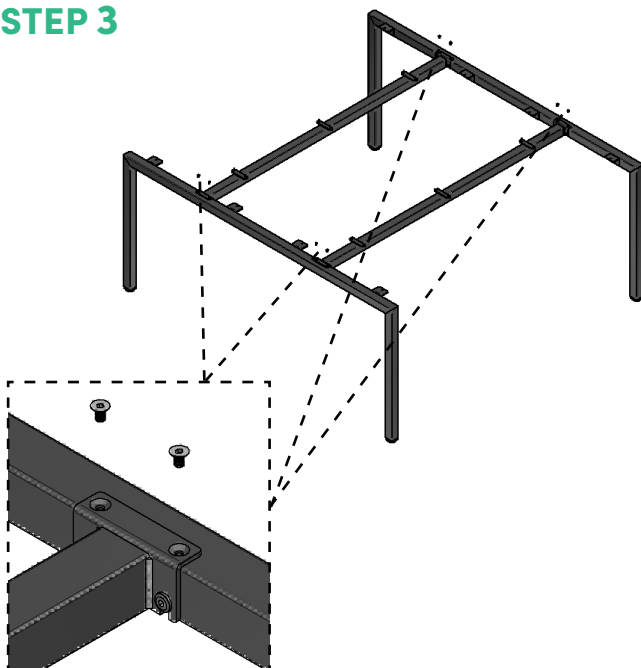

Attach the beam onto the leg frame, tighten flat head bolts on the side of the leg frame.
Do not overtighten – excessive force may strip threads or damage component.

STEP 4

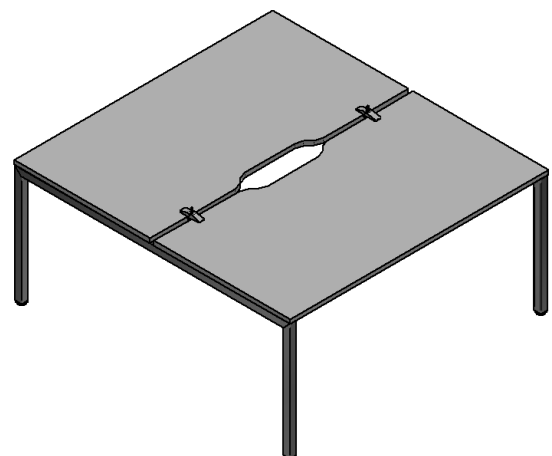



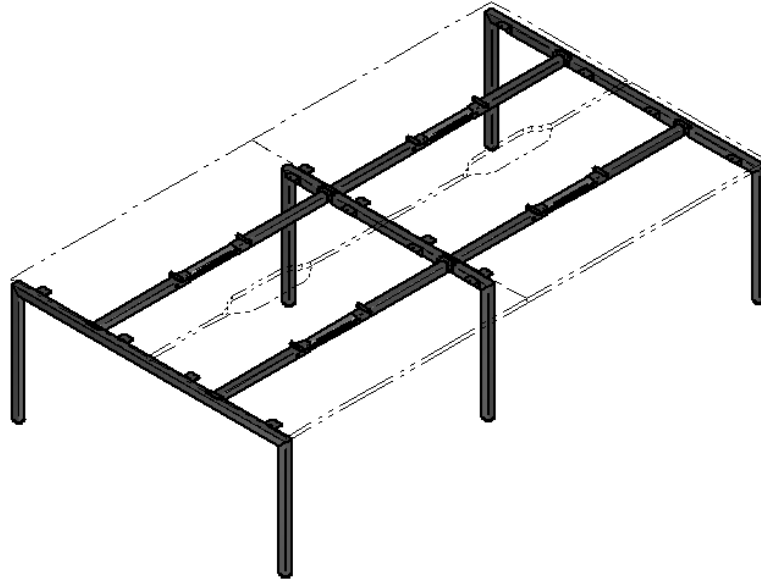

Place Desktops onto the frame.
Note: If centre screens have been supplied place the screen brackets between the top before attaching the leg and beam frame to the desktop.

BACK-TO-BACK 4POD

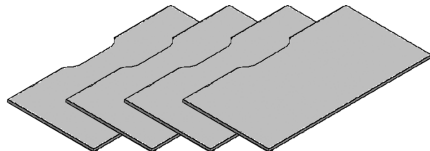
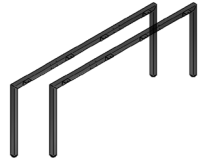
PARTS LIST

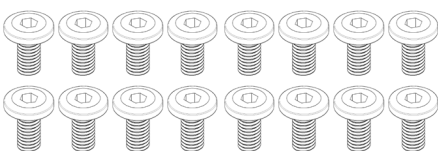

NO.	NAME	QUANTITY	IMAGE
1	Desk Top	4pcs	
2	End Leg Frame	2pcs	
3	Middle Leg Frame	1pc	
4	Extendable Beam	4pcs	
5	Wood Screw	32pcs	
6	CSK Bolt	16pcs	
7	Flat Head Bolt	16pcs	

BACK-TO-BACK 4POD

ASSEMBLY INSTRUCTION

STEP 1

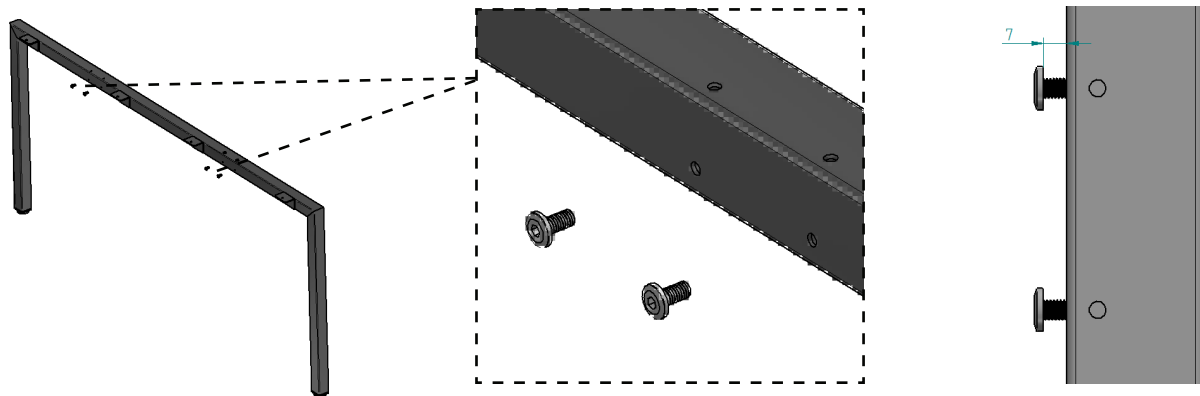

Install flat head bolts to the side of the leg. Note: Ensure the flat head bolt is installed with the head protruding approximately 7mm from the surface. This spacing is necessary for the next step.

STEP 2

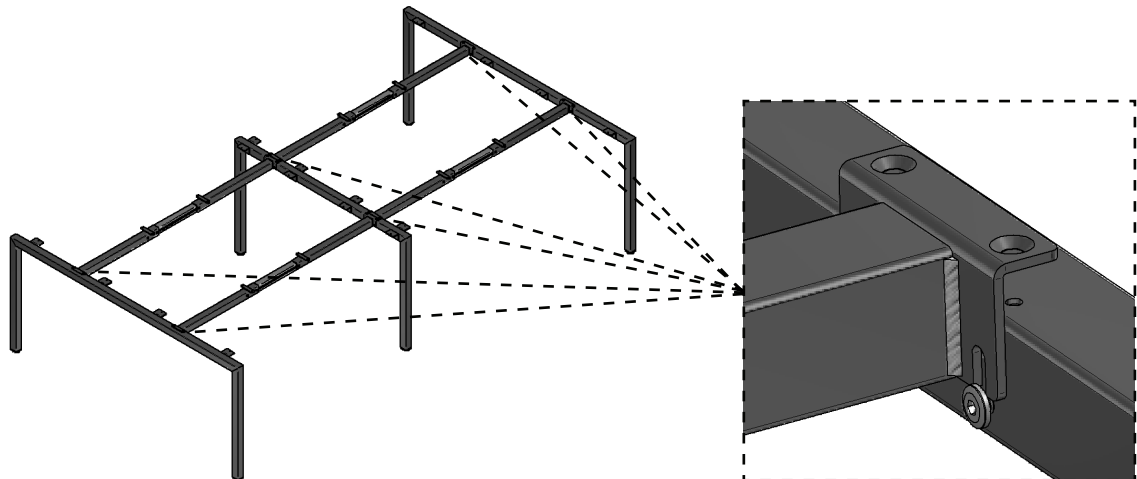

Attach the beam to the legs.

STEP 3

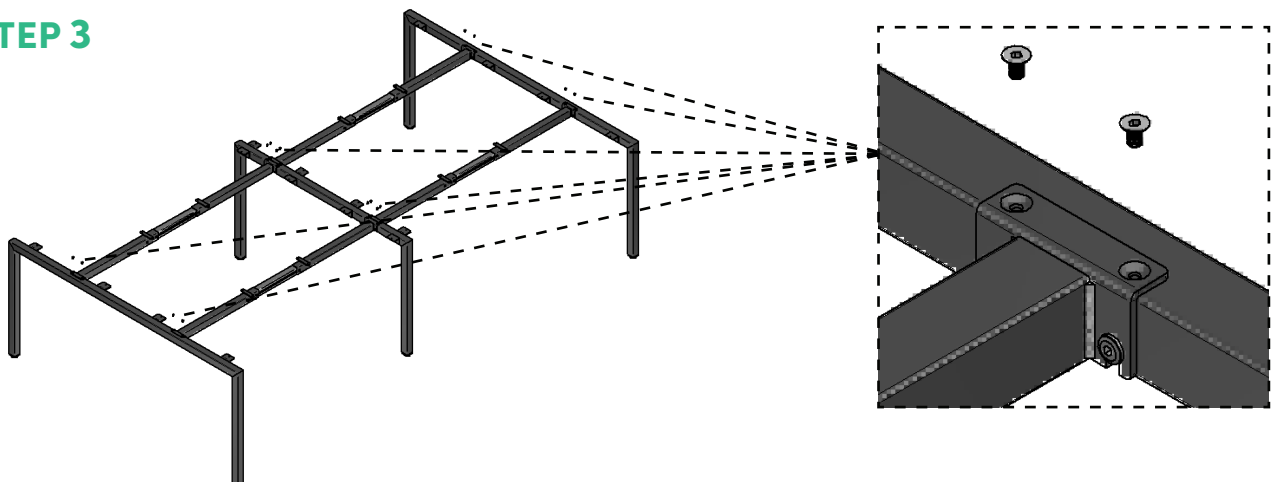

Attach the beam onto the leg frame, Tighten flat head bolts on the side of the leg frame.
Do not overtighten – excessive force may strip threads or damage component.

BACK-TO-BACK 4POD

ASSEMBLY INSTRUCTION

STEP 4

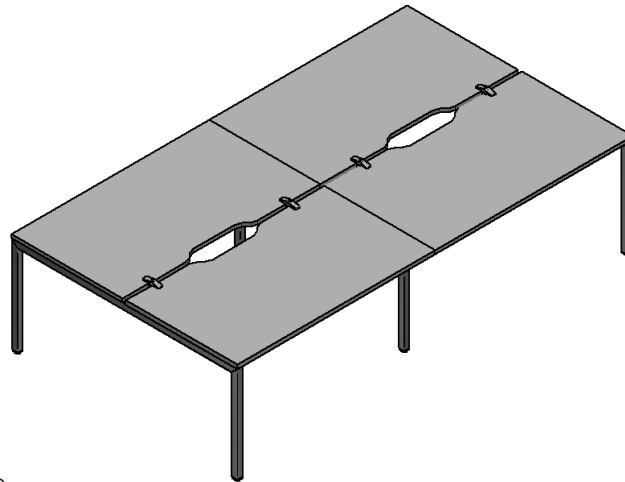

Place Desktops onto the frame.

Note: If centre screens have been supplied place the screen brackets between the top before attaching the leg and beam frame to the desk top.

STEP 5

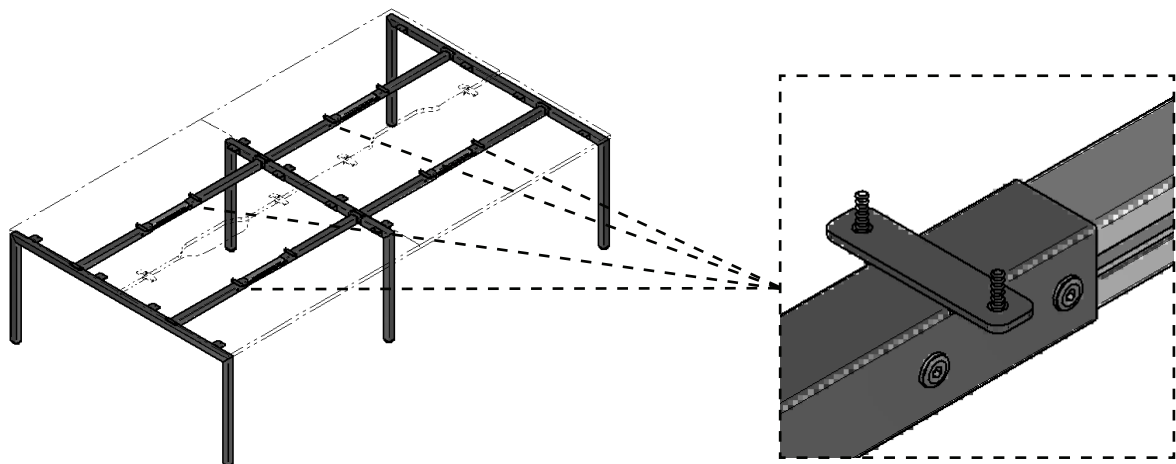

Tighten flat head bolts on the front and back of the beam.

STEP 6

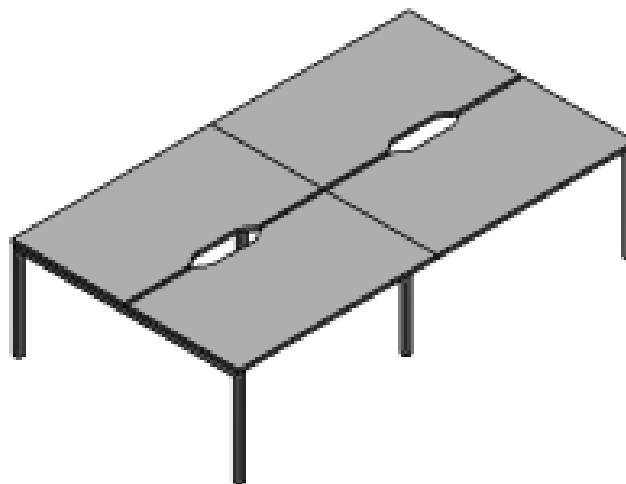

CORNER WORKSTATION

PARTS LIST

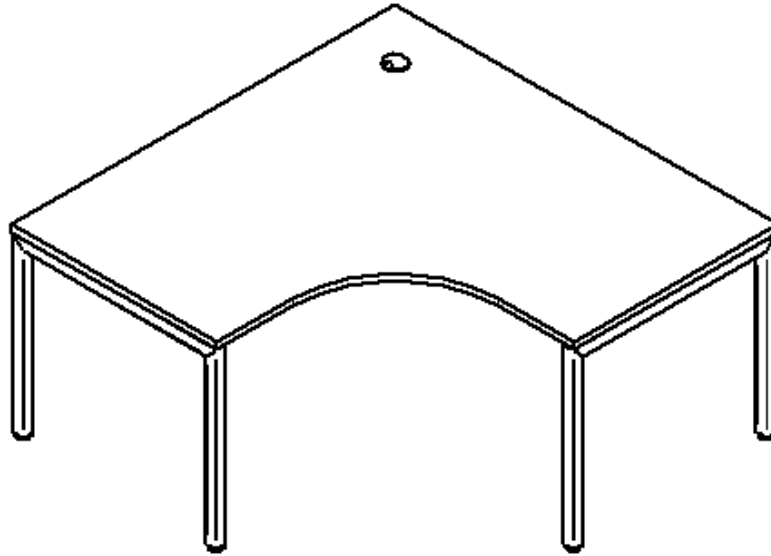

NO.	NAME	QUANTITY	IMAGE
1	Desk Top	1pc	
2	Leg Frame	3pcs	
3	Fixed Beam	1pc	
4	Extendable Beam	1pc	
5	Cable Entry	1pc	
6	Wood Screw	18pcs	
7	CSK Bolt	6pcs	
8	Flat Head Bolt	6pcs	

CORNER WORKSTATION

ASSEMBLY INSTRUCTION

STEP 1

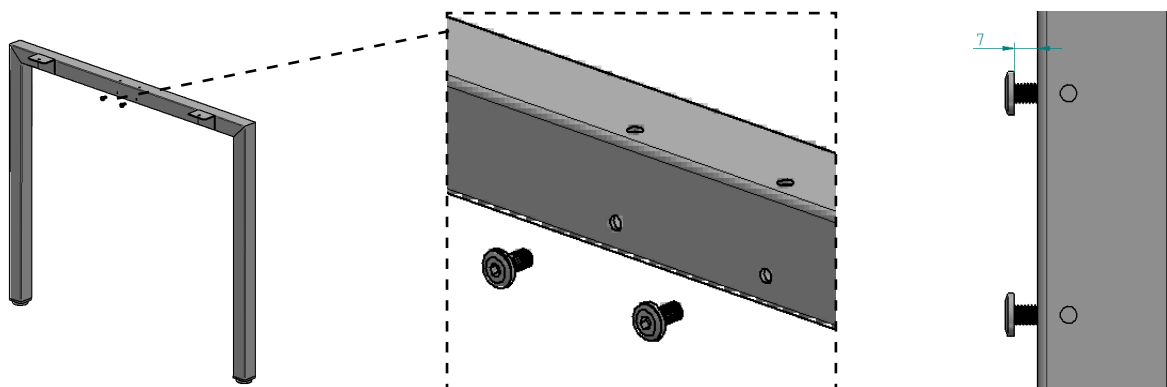

Install flat head bolts to the side of the leg. Note: Ensure the flat head bolt is installed with the head protruding approximately 7mm from the surface. This spacing is necessary for the next step.

STEP 2

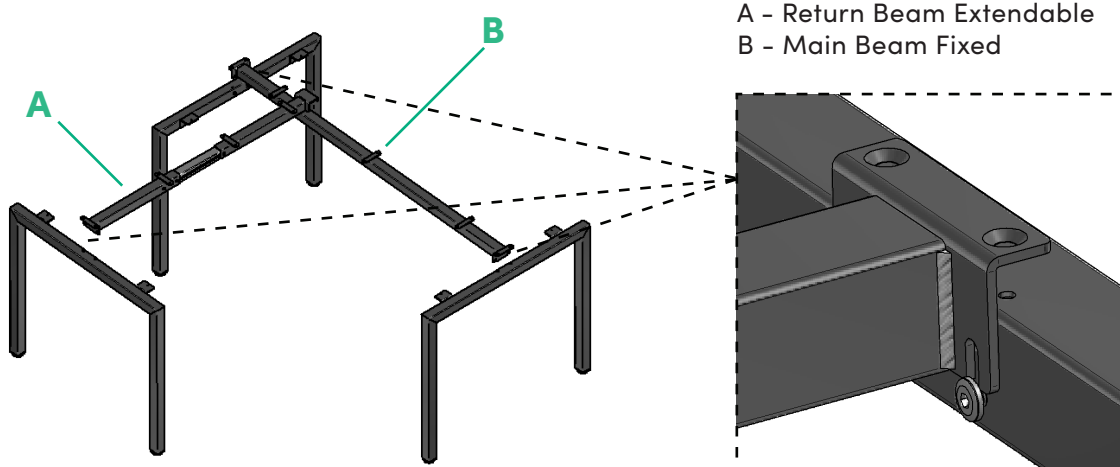

A - Return Beam Extendable
B - Main Beam Fixed

Attach the beam to the legs.

STEP 3

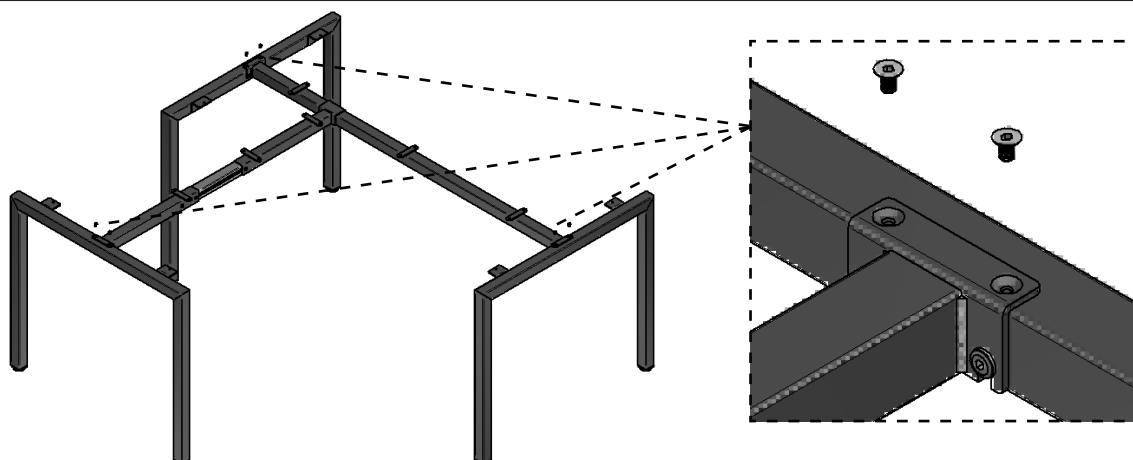

Attach the beam onto the leg frame, tighten flat head bolts on the side of the leg frame.
Do not overtighten – excessive force may strip threads or damage component.

CORNER WORKSTATION

ASSEMBLY INSTRUCTION

STEP 4

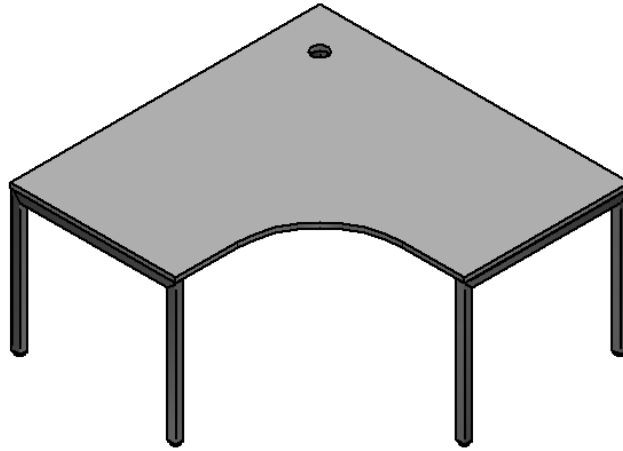

Place desktops onto the frame. Attach the frame to the desktop.

STEP 5

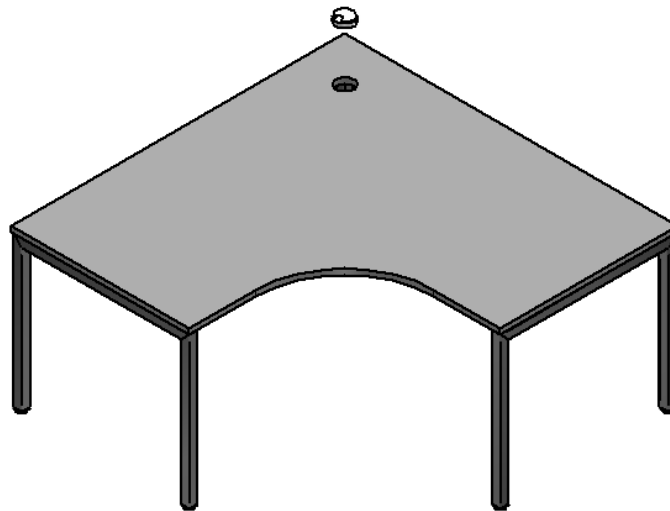

Install cable port.

STEP 6

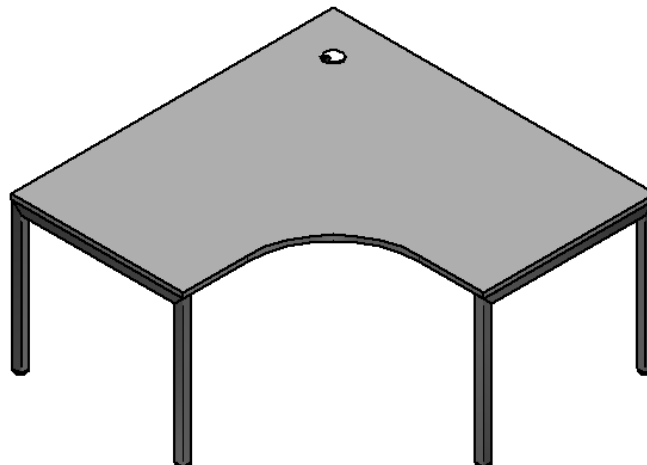

GENERAL CARE – INFORMATION

- Avoid scourers and abrasives as they will damage the surface.
- Don't place hot objects, electrical appliances or pots straight from the oven or cooker onto your laminate surface.
- Don't cut on the laminate surface.
- Keep waxes and polishes well away as they dull the natural shine.
- Do not use strongly acidic, alkaline cleaners or bleach for normal cleaning as these might etch the surface.

GENERAL CARE – STREAKS

Streaky marks sometimes show on dark colours after cleaning. An all-purpose cleaner such as Mr. Muscle Surface & Glass or Ajax Spray n Wipe usually removes them.

GENERAL CARE – GREASE

Using a mild dishwashing detergent in water will remove greasy marks. Dab, wait and wipe away. Finish with an all-purpose cleaner such as Mr. Muscle Surface & Glass or Ajax Spray n Wipe.

GENERAL CARE – SPILLS

Laminate surfaces resist staining from most household chemicals. With some accidental spills however, prompt action is essential. Wipe off beetroot, grape and berry juices, first aid preparations, concentrated bleach, oven cleaners, dishwasher detergents, artificial dyes, hair colouring and solvent based pen ink immediately. Specialty glues such as Super Glue must also be removed straight away with acetone (nail polish remover).

GENERAL CARE – STAINS

If the stain won't budge with Mr. Muscle Surface & Glass, try methylated spirits or dab the stain with a diluted bleach mixture (1 part bleach to 8 parts water); leave for 3 minutes then wash off with water and dry. Finish off with Mr. Muscle Surface & Glass. Only as a last resort if a stain persists try 2 or 3 rubs with a crème cleanser or white toothpaste, wash and dry. Please note that bleach or these abrasive cleaners may irreversibly damage the laminate surface.

GENERAL CARE – SCRATCHES

Laminate surfaces will withstand normal wear and tear, but can be damaged by scratching or cutting with utensils, knives and unglazed pottery. Darker colours will show scratches more readily than lighter colours. In general, dark colours and high gloss surfaces require more care and maintenance than lighter colours or lower gloss colours. To minimise scratching, always place and lift objects from the surface – never drag or slide them across the surface.

Accent

WARRANTY

REGISTRATION

At Accent Group, we are committed to delivering not only exceptional products but also exceptional customer experiences. We take immense pride in crafting each item with the utmost care to meet your expectations and your purchase is backed by our 15-year Warranty (terms and conditions apply). To make the most of this extended warranty and to facilitate any future claims seamlessly, we kindly request you to complete our Warranty Registration Form by scanning the QR code below. Providing us with your details will enable us to serve you better and ensure your peace of mind throughout the warranty period.

View full Warranty details on our website – www.accentgroup.co.nz

CUSTOMER PRODUCT REVIEW TEAM

As a company committed to excellence, we continuously seek ways to enhance our offerings and deliver the finest in the NZ market. We invite you to take part in a Customer Product Review. Your valuable feedback matters to us, and joining the team is effortless. Approximately three months after your product delivery, one of our team members will reach out to you for a brief call. During this conversation, we will enquire about your product experience. Your insights on what's working well and what's not, whether the products have met your expectations, and if you would consider purchasing from Accent again are highly appreciated.

By joining our Customer Product Review Team, you play an integral role in shaping the future of our products, ensuring they align perfectly with your needs and preferences. Your voice will guide us in crafting even better offerings that resonate with customers like you.

We are truly excited about this opportunity to collaborate with you closely.

If you wish to participate in the program, please tick YES when you complete your Warranty Registration. Every quarter we'll select 4-5 customers to take part in the 3 month product review each customer we receive feedback from will receive a \$50 Prezzy card.

Don't hesitate to reach out to us if you have any queries or need assistance, give our team a call on 0800 826 126. Thank you again for choosing Accent Group products.

Best regards,
The Accent Group Team

Accent

SCAN TO REGISTER



0800 126 826 | support@accentworkspaces.co.nz

19



0800 126 826

support@accentworkspaces.co.nz

22 Hood Street Wellsford, Auckland 0900 New Zealand