

# Broadway 2 Legs Desk

## User Instructions

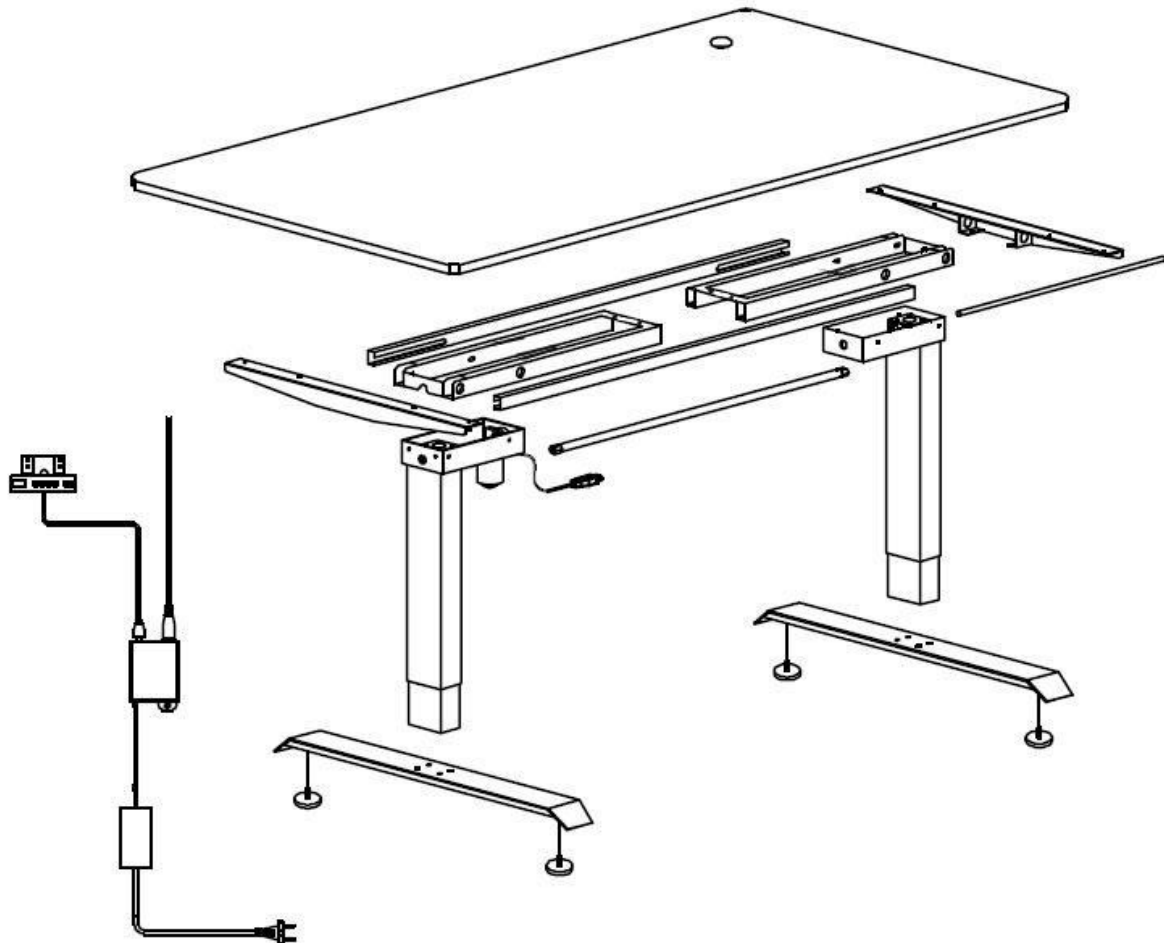

### Attention:

The control box ( Item 3) has balancing device inside, when testing, please do not hold the control box in your hand, please fix onto the frame.

Frame will not rise or fall if the control box detects that it is tilted.

## a. Parts list

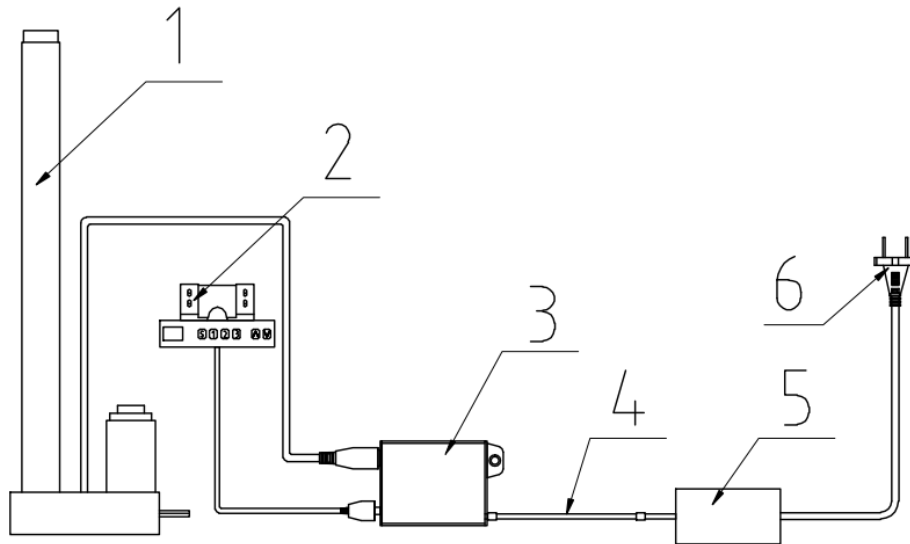

1. Lifting Column	-----	2pc
2. Handset	-----	1pc
3. Control Box	-----	1pc
4. Patch Cord	-----	1pc
5. AC Adaptor	-----	1pc
6. Power Cord	-----	1pc

## b. Technical Specifications

1. Input-----	110~240VAC
2. Output Power -----	24VDC
3. Load Capacity -----	800N
4. Speed -----	20mm/s
5. Stroke -----	400mm
6. Min Install Dimension -----	675mm
7. Operation Temperature -----	0-40°C
8. Duty Cycle -----	Max.10% or 2min on and 18min off

### c. Direction for Use

1. Correctly connect the Control Box, Handset, Power Cord, Lifting Column & Patch Cord. (Picture 1).
2. Plug the power cord into 110~220VAC outlet The LCD display will show "PON" for seconds indicating a positive power connection system resetting.

After resetting the LCD display will display **680mm**, reset finished.

#### **Reset(Initialization):**

**Press and hold the down button until handset displays "rES". The desk will begin to lower until it reaches the lowest height then it will rise slightly. Reset finished. Then release the down button.**

3. After reset, press and hold "UP" button, lifting column will rise, release to stop.
4. After reset, press and hold "DOWN" button, lifting column will lower, release to Stop.

#### **Setting Memory Positions:**

After pressing and holding UP/DOWN button to a height, press button M first, then press button 1, this height will be remembered by button 1.

Still pressing and holding UP/DOWN button to another height, press button M, then press button 2, this height will be remembered by button 2.

The same way, the button 3 can remember other heights. After memory, press 1/2/3 button, desk will motion to the height it remembers, press "UP" and "DOWN" button. The motion will be stopped.



## d. Trouble Shooting

If the LCD Controller displays error codes when raising or lowering the desk, a reset will be required.

1. Motor error (E01)

Control box can not detect motor halt plate signal or Control box detect one lifting column is over loaded. This is a safety protection.

Pls take away any large loads from the desk top and reset the controller. Should a reset fail to resolve the issue one or more motors will need to be replaced.

2. Control box temperature protection (HOT)

This indicates that the control box temperature is above 75°C or the system has been in continuous use for 2min or more. The lifting columns are locked out for up to 18mins as a safety precaution. For an urgent reset, unplug the power cord.

3. Overload protection (E07)

Desk load in excess of 100kg, user needs to reduce load, then reset or just need to wait for 3 seconds, it will recover.

4. Low Voltage protection (E08)

Power Voltage is too low for the controller, This is a safety cut out protection. system will recover as soon as voltage returns to normal.

5. High Voltage protection (E09)

Power Voltage is too high for the controller, This is a safety cut out protection. system will recover as soon as voltage returns to normal.

6. Control Box or Handset Issue (E10)

If Handset display E10 and will not disappear, control box or handset is broken.

## e. Warranty Notice

1. This product must be used under the correct technical parameters.
2. Keep away from liquids, corrosives, gases and dusty environments.
3. Do not open any of the components, doing so will void any and all service support and manufactures warranties.



"1" Button - Return to previous menu

"UP" / "DOWN" Button - Select menu

"M" Button - Confirm menu

#### f. **Changing between cm and inch-1Un**



Keep pressing Button "M" for 3 seconds, Handset will display "S---", then release pressing Button "M" and press Button "M" again, the code "1Un" will then appear. Press Button "M" to enter.

1. It will display **Si**, You can Press "M" button to preserve cm display and pls wait for 2 seconds it will display current height(cm).
2. After it displays **Si**, you can press Button "Up"/"Down" to change it to **in**, Press Button "M" to preserve Inch display and pls wait for 2 seconds it will display current height(Inch).

#### g. **Setting Handset display brightness-2br**

1. Keep pressing Button "M" for 3 seconds. Handset will display "S---", then release pressing Button "M" and press Button "M" again to enter, the code "1Un" will then appear.
2. Press button "Up"/"Down" to be **2br**. Then press button "M" to enter, this will display current display brightness level (L/**n**/H).  
L: Means low brightness, **n**: Means normal brightness, H: Means high brightness.
3. Press button "Up"/"Down" to select your favourite brightness level, then press button "M" to preserve and quit, pls wait for 2 seconds and it will display current height.

## **h. Adjusting Sound-3bE**

1. Keep pressing Button “M” for 3 seconds. Handset will display “S---”, then release pressing Button “M” and press Button “M” again to enter, the code “1Un” will then appear.
2. Press button “Up”/”Down” to be “3bE”,  
Then press button “M” to enter, this will display current sound situation (OFF/ ).  
OFF: Means handset has no sound, ON: Means handset has sound.
3. Press button “Up”/”Down” to select OFF or , then press button “M” to preserve and quit, pls wait for 2 seconds and it will display current height.

## **i. Adjust upward sensitivity-4Fu**

1. Keep pressing Button “M” for 3 seconds. Handset will display “S---”, then release pressing Button “M” and press Button “M” again to enter, the code “1Un” will then appear.
2. Press button “Up”/”Down” to be “4Fu”, Then press button “M” to enter, this will display current upward sensitivity level (L5). We have 9 levels of upward sensitivity, from L1 to L9, L1 is the most sensitivity, L9 is the least sensitivity. L5 is our factory setting upward sensitivity.
3. Press button “Up”/”Down” to select your favourite upward sensitivity level, then press button “M” to preserve and quit, pls wait for 2 seconds and it will display current height.

## **j. Adjust downward sensitivity-5Fd**

1. Keep pressing Button “M” for 3 seconds. Handset will display “S---”, then release pressing Button “M” and press Button “M” again to enter, the code “1Un” will then appear.
2. Press button “Up”/”Down” to be “5Fd”.  
Then press button “M” to enter, this will display current upward sensitivity level (L5).  
We have 9 levels of upward sensitivity, from L1 to L9, L1 is the most sensitivity, L9 is the least sensitivity. L5 is our factory setting upward sensitivity.

3. Press button “Up”/”Down” to select your favourite upward sensitivity level, then press button “M” to preserve and quit,pls wait for 2 seconds and it will display current height.

## k. Adjust Vibration Sensitivity-6FS

1. Keep pressing “M” for 3 seconds.Handset will display “S---”, then release pressing Button “M” and press Button “M” again to enter,the code “1Un” will then appear.
2. Press button “Up”/”Down” to be “6FS”,Then press button “M” to enter, this will display current vibration sensitivity level (L5).We have 9 levels of vibration sensitivity,from L1 to L9,L1 is the most sensitivity,L9 is the least sensitivity.L5 is our factory setting vibration sensitivity.
3. Press button “Up”/”Down” to select your favourite vibration sensitivity level, then press button “M” to preserve and quit,pls wait for 2 seconds and it will display current height.

## I. Adjust the lowest height display and height range-7SH

1. Keep pressing Button “M” for 3 seconds.Handset will display “S---”, then release pressing Button “M” and press Button “M” again to enter,the code “1Un” will then appear.
2. Press button “Up”/”Down” to be “7SH”,Then press button “M” to enter, this will display  $H_i b$ ,you also can press button “Up”/”Down”,so that it will display  $L_i L_i$ , and  $L_i H_i$ .

$H_i b$ :Mean to set the lowest position display height.

$L_i L_i$ :Mean to set a new lowest position

$L_i H_i$ :Mean to set a new highest position

3. Press button “Up”/”Down” to be  $H_i b$ ,Then press button “M” to enter,will display current lowest height,you can Press button “Up”/”Down” to adjust the lowest height display,then press button “M” to preserve and quit,pls wait for 2 seconds and it will display new lowest height.
4. Press button “Up”/”Down” to be  $L_i L_i$ ,Then press button “M” to enter,will display current lowest height,you can Press button “Up” set a new lowest position,then press button “M” to preserve and quit,pls wait for 2 seconds and it will display height.New Lowest position finished setting.

5. Press button "Up"/"Down" to be **L H**, Then press button "M" to enter, will display current highest height, you can Press button "Down" to set a new highest position, then press button "M" to preserve and quit, pls wait for 2 seconds and it will display height. New Highest position finished setting.
6. After setting, desk can only motion between new lowest position and new highest position.

### **m. Switching between modes-8Hc**

1. Keep pressing Button "M" for 3 seconds. Handset will display "S---", then release pressing Button "M" and press Button "M" again to enter, the code "1Un" will then appear.
2. Press button "Up"/"Down" to be "8Hc", Then press button "M" to enter, this will display current mode: "001". you also can press button "Up"/"Down", so that it will display "002".

We have two modes for your choosing.

"001" mode: You need to keep pressing up or down button so that desk will motion.

"002" mode: You only need to press one time up or down button, the desk will motion, click press any button the motion will be stopped.

3. Press button "Up"/"Down" to select your favourite mode (001 or 002), then press button "M" to preserve and quit, pls wait for 2 seconds and it will display current height.

### **n. Adjust time reminder-9St**

1. Keep pressing Button "M" for 3 seconds. Handset will display "S---", then release pressing Button "M" and press Button "M" again to enter, the code "1Un" will then appear.
2. Press button "Up"/"Down" to be "9St", Then press button "M" to enter, this will display 0.0H. (Mean no time reminder, H mean hour)
3. Press button "Up"/"Down" to select your favourite reminder time (Like 1.5H mean 1.5hour), then press button "M" to preserve and quit, pls wait for 2 seconds and it will display current height.

Note:

*When handset time reminder beep, press any button, the beep will disappear. The time reminder beep will last for 30 seconds for 1 time, if no pressing any button.*



## **o. Adjust bounce height-10H**

1. Keep pressing Button “M” for 3 seconds. Handset will display “S---”, then release pressing Button “M” and press Button “M” again to enter, the code “1Un” will then appear.
2. Press button “Up”/”Down” to be “10H”, Then press button “M” to enter, this will display current bounce height.
3. Press button “Up”/”Down” to set a favourite bounce height, then press button “M” to preserve and quit, pls wait for 2 seconds and it will display current height.

## **p. Restore factory Settings-11r**

1. Keep pressing Button “M” for 3 seconds. Handset will display “S---”, then release pressing Button “M” and press Button “M” again to enter, the code “1Un” will then appear.
2. Press button “Up”/”Down” to be “11r”, press button “M” to enter, **FrE** will flash.
3. Then press button “M” to preserve and quit, “rES” will appear, need a **reset** to finish restoring factory setting. (About Reset, pls referencing to Step C)

## **q. Fatigue test mode-12d**

1. Keep pressing Button “M” for 3 seconds. Handset will display “S---”, then release pressing Button “M” and press Button “M” again to enter, the code “1Un” will then appear.
2. Press button “Up”/”Down” to be “12d”, Then press button “M” to enter. It will appear **PH\_**, Press 5 times button “1” continuously, you can enter into fatigue mode selecting menu. There will be 5 modes for your choosing.

OFF: No fatigue test.

51: Level 1 fatigue test, continue working, no stop.

52: Level 2 fatigue test, Upward and Downward 1 time then rest for 4 minutes.

53: Level 3 fatigue test, Upward and Downward 1 time then rest for 6 minutes.

54: Level 4 fatigue test, Upward and Downward 1 time then rest for 10 minutes.

3. Pls press “up” and “down” to select your favourite fatigue mode, Then press button “M” to preserve.

4. You can press “UP” button to begin fatigue test, also you can quit the fatigue test by unplugging the power cord.

## r. Handset Lock

1. Keep pressing “Up” and “Down” button for 5 seconds, Handset will lock.
2. Keep pressing “Up” and “Down” button for 5 seconds, Handset will be unlock.